

# LabView Based Navigational Aids to Predict the Position of Automated Guided Vehicles with Ultrasound and Radio Frequency Sensing

Ravindra Thamma  
Central Connecticut State University  
[thammarav@mail.ccsu.edu](mailto:thammarav@mail.ccsu.edu)

E. Daniel Kirby  
Central Connecticut State University  
[kirbyerd@ccsu.edu](mailto:kirbyerd@ccsu.edu)

Gregory Marshall  
Charter Oak State College  
[marshallg@my.ccsu.edu](mailto:marshallg@my.ccsu.edu)

Hugo Cuervo Garcia  
University of Leon  
[hcuervogarcia@gmail.com](mailto:hcuervogarcia@gmail.com)

Mark Rajai  
California State University  
[mark.rajai@csun.edu](mailto:mark.rajai@csun.edu)

## Abstract

This research develops a graphical LabVIEW virtual instrument (VI) ultrasonic distance measurement system based on time-of-flight theory to estimate AGV triangulation position. The distance measurement unit, or sub VI, communicates directly with the microcontrollers that contain ultrasound transmitters and RF receivers. The signal from the ultrasound receiver is processed via a custom built circuit on the mobile unit. The sub VI generates pulse of 40 KHz via a NI-6602 32-bit counter timer card. As the pulse is received and processed on the mobile unit, it then transmits an RF signal back to the RF receiver on the base unit. The counter timer card will repeat the signal to the sub VI to begin the distance calculation once the RF receiver captures a signal from the mobile unit.

## Introduction

A pinnacle of development in the manufacturing system was the invention of the Unmanned Guided Vehicle (UGV), a material handling equipment that works in cells without human intervention [1]. The application of UGVs in Flexible Manufacturing Systems (FMS) has allowed increased implementation of automated material handling systems, becoming an essential part of FMS due to their flexibility and adaptive behavior [2]. The challenge of UGVs is finding reliable tracking methods to accurately locate and guide these vehicles in a production environment. Currently, the most widely-used method for UGV tracking is the Global Positioning System (GPS). However, due to the GPS receiver's large size, limited accuracy, and satellite visibility requirements, this system is not appropriate to use inside an enclosed area [3].

Other methods of UGV navigation include: 1) wire guided, 2) inertial guided, 3) laser guided, 4) grid guided, and 5) chemical path guided. In these navigation systems, the UGVs guidance is based on a fixed track pattern, transponders, or laser targets. A UGV using these guidance methods cannot deviate from their pre-established route [4]; thus, their flexibility is greatly limited due to their physical track [5]. If the track system can be eliminated and the UGVs guided reliability without these physical stationary devices, flexibility can be enhanced.

Therefore, a UGV that meets the principles of the FMS requires the development of a UGV guidance system that is free of stationary tracking patterns, targets, or other fixed devices. Developing a trackless UGV includes a variety of modifications to the current system. A fundamental requirement is the ability to accurately locate the UGV for navigation. The author in this paper demonstrates a new experimental trackless navigational aid to enhance the flexibility of a UGV.

## **Literature Review**

The SENCAR UGV uses infrared beacons mounted on the ceiling to triangulate the position [6]. AT&T Labs has also developed a low cost infrared triangulation location system [7]. A low cost ultrasonic 3D position estimate system has been developed that uses the actual time of flight (TOF) from the transmitter to the receiver [8, 9]. Another team has developed an ultrasonic positioning system based on the difference between the TOF of the sound waves for various sensors [10].

The matrix-based model is an improvement over conventional triangulation technique for coordinate positioning [11]. A few researchers have used Fuzzy triangulation to identify a robot's positions and orientation [12]. One typical algorithm used for triangulation method computation is described in [13]. However, most such algorithms are proprietary because the solutions are non-trivial [14].

One of the methods used to find coordinates is installing three or more transmitters at known fixed locations and one receiver on board the UGV [14]. With a single receiver on board, however, it may not be possible to receive signals in any given direction, which limits the accuracy. This means the transmitter has to direct signal to the receiver directly or in other words there should be a line of sight in between the transmitter and the receiver. And all the transmitters have to face the receivers in order to catch the signal or else there can be error.

Another method uses three or more active transmitters mounted on the known location. The sensor rotates and measures the three angles. This system helps in measuring the coordinates and unknown vehicle rotation. In order to overcome the problems powerful transmitters to ensure omni directional transmission over large distances and it results in cone shape propagation [14]. As a result of this cone propagation the transmitters are not visible in many areas resulting triangulation not possible.

A new system reduced errors by using floating points for triangulation and increasing the flexibility of their system. An acoustic cone made of aluminum and placed it above the receiver allowing the ultrasonic sound waves to be collected from any direction [15]. One of the disadvantages to this system is the cost and use of many components.

A detailed analysis on three-point triangulation algorithms and ran computer simulations to verify the performance of different algorithms [16]. The results are summarized as follows:

The geometric triangulation method works consistently only when the robot is within the triangle formed by the three beacons. There are areas outside the beacon triangle where the geometric approach works, but these areas are difficult to determine and are highly dependent on how the angles are defined.

- The *Geometric Circle Intersection* method has large errors when the three beacons and the robot all lie on, or close to, the same circle.
- The *Newton-Raphson* method fails when the initial guess of the robot' position and orientation is beyond a certain bound.
- The heading of at least two of the beacons was required to be greater than 90 degrees. The angular separation between any pair of beacons was required to be greater than 45 degrees.

A unique triangulation system based on two different ultrasound signals and Radio Frequency using four transmitters' at different locations and eight receivers fixed on a UGV. This method requires no line of sight or specific angle to receive the signal from transmitter. Thus vehicle can rotate in any angle and move anywhere in a given specific region. At the same time it was possible to estimate the position coordinates and orientation of vehicle. The new system shows that the vehicle can be more flexible and angular restriction does not bind its movement [17, 18].

In summary, it appears that none of the above methods alone is always suitable, but an intelligent combination of two or more methods helps overcome the individual weaknesses [14]. There are systems available in the market to overcome some of the above-mentioned problems. But, these systems are too large and expensive for operation [14, 15]. To overcome above-mentioned problems, there is a need for a smaller and inexpensive system.

The following equations used for distance and orientation of the mobile unit were developed by Dr. Thamma [17, 18]. The equations were translated into LabVIEW graphical code by using formula nodes.

**Estimation of Distance from Base Station:**

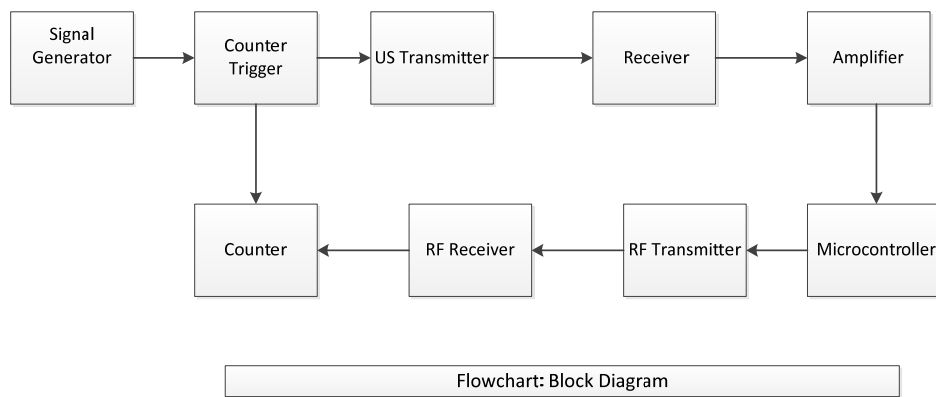

**Figure 1: System Block Diagram**

The Distance Measuring System (DMS) was used to calculate the distance of the Test Unit from its location. The DMS consists of three parts-the base station, a mobile unit and the LabVIEW virtual instruments (VI). The distance is calculated by measuring the flight time of the ultrasonic pulse to the mobile unit. The position of the mobile unit varies over time and the base station remains fixed. The base station is designed to recognize response and calculate the time of flight. The flight time was

calculated by the ultrasound sub VI. The ultrasound sub VI contains a case structure with a state for each of the four receivers. The sub VI generates a 5 us pulse @ a frequency of 40 Hz via a NI 6602 32 bit counter timer card. The pulse is read by the Ultrasound receiver on the mobile unit. Once the signal is received, the mobile unit transmits an RF signal back to the RF receiver on the base unit. The counter timer card will send a signal to the sub VI to begin the distance calculation once the RF receiver captures a signal from the mobile unit. The distance is calculated by:

$$d = [ V(Ta-t) ], \text{ (Equation 1)}$$

where  $d$  = distance (in.),  $Ta$  = average flight (s) and  $t$  = elapsed time (s) across the electronic circuit.

Four base units, equally spaced 27.5 in. apart were secured to the two wooden test stands shown in Figure 2. The base unit ping sensors were then wired to terminal strips with 10k ohm resistors and 1N4001 diodes as shown in Figure 3.

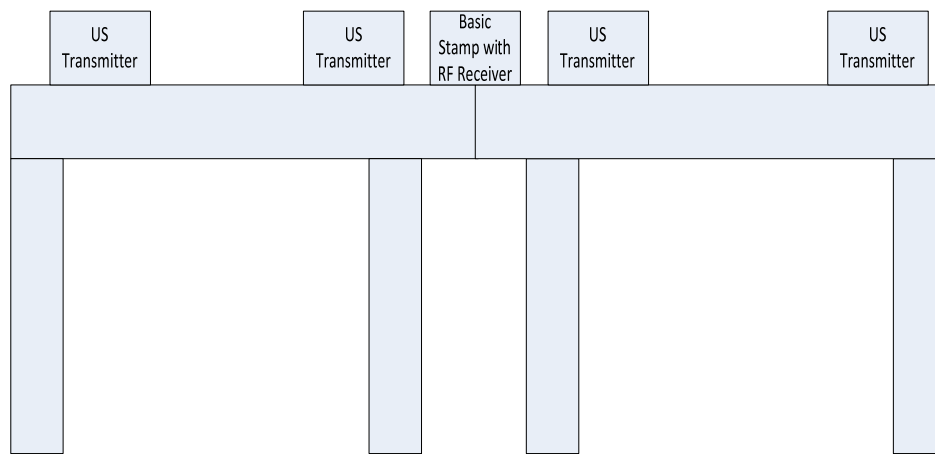

**Figure 2: Base Stand Configuration**

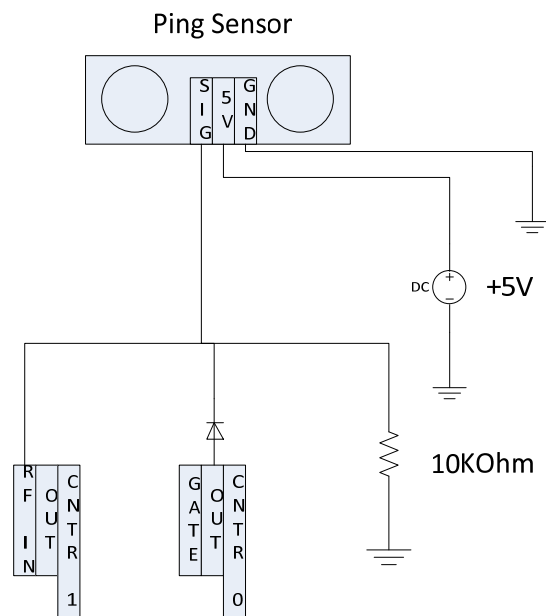

**Figure 3: Ping Sensor Circuit [19]**

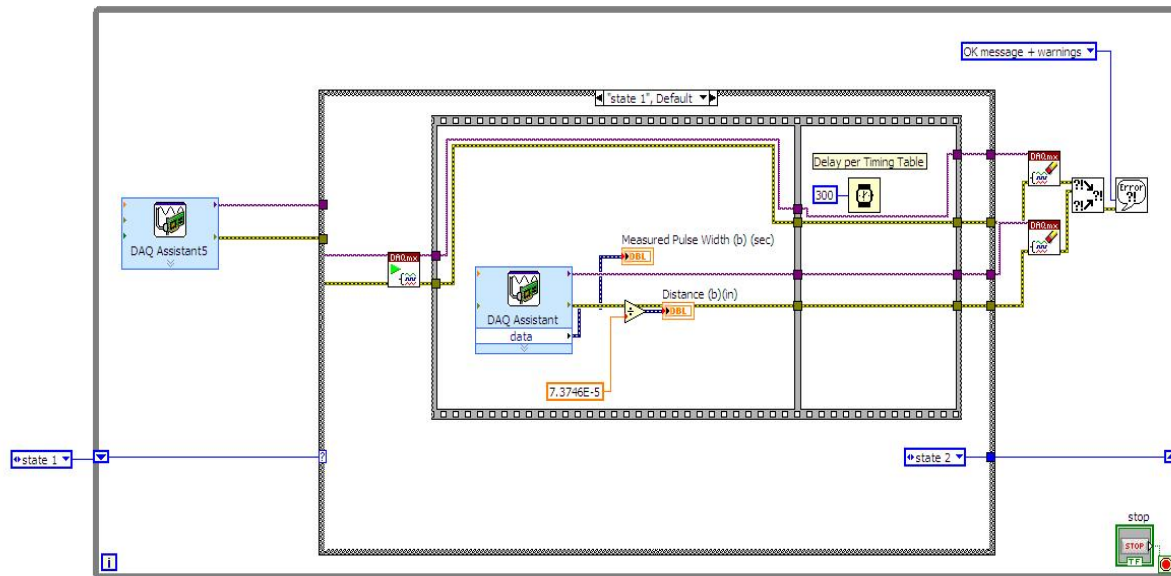

**Figure 4: Ultrasound Sub VI**

### Mobile Unit

The mobile unit consisted of a Parallax BS2 microcontroller with an ultrasound receiver from a Parallax #28015 and Parallax #27996 transmitter. The ultrasound receiver signal was amplified by a custom built amplifier as shown in Figure 5.

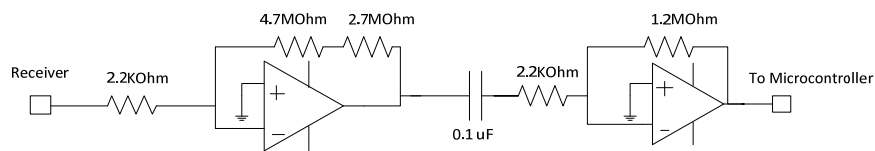
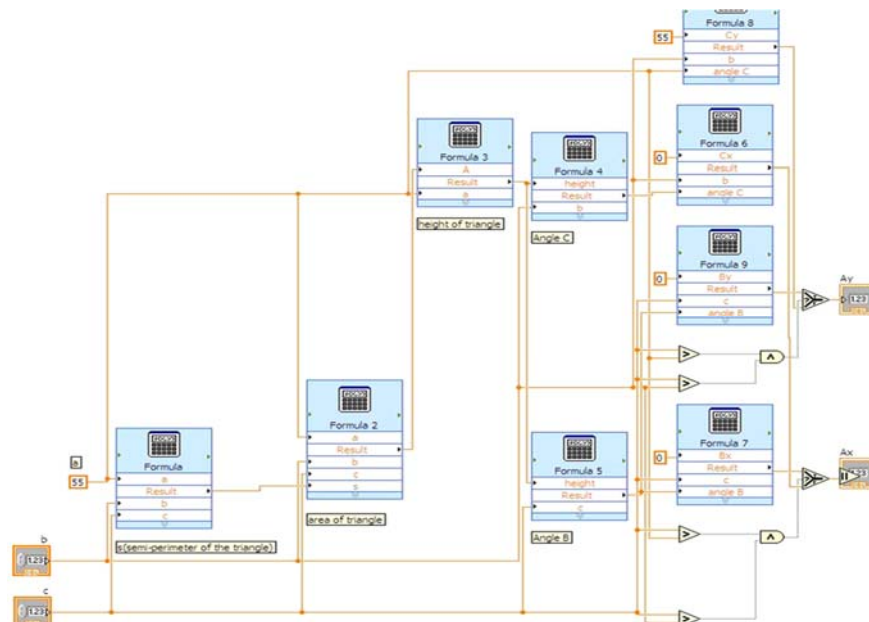

**Figure 5: Custom Built Amplifier [1]**

The amplified signal was feed into a BS2 microcontroller. The microcontroller triggered the Parallax #27996 RF Transmitter to transmit a signal back to the Parallax#27981 RF 433Mhz receiver on the base station.

### Algorithm for Head and Tail Position

The LabVIEW sub VIs shown in Figures 6 and 7 were created that incorporate the following step-by-step formulas.



**Figure 6: Head Distance Sub VI**

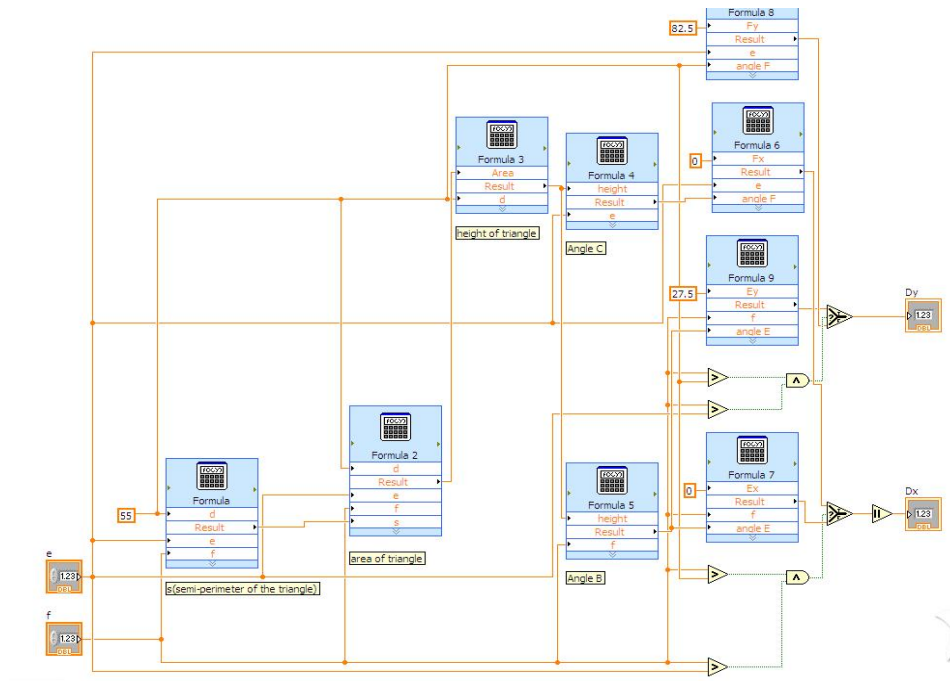

**Figure 7: Tail Distance Sub VI**

Step 1: Obtain the sides of the triangle. The base dimension of the triangles is 27.5”-The distance between the ping sensors.

Step 2: Before we find the area of the triangle we must find the semi perimeter (s) of each triangle by:

$$s = \frac{1}{2} (a + b + c) \quad (\text{Equation 2})$$

Next, calculate the area. Of each triangle

$$\text{Area} = \sqrt{s * (s - a) * (s - b) * (s - c)} \quad (\text{Equation 3})$$

Step 3: The height (h) of each triangle is found by:

$$h = \frac{2 * \text{Area}}{\text{base length}} \quad (\text{Equation 4})$$

Step 4: The Angle of Vertices B and C was calculated by:

$$\text{Angle C} = \sin^{-1} \left( \frac{\text{height}}{b} \right) \quad (\text{Equation 5a})$$

$$\text{Angle C} = \sin^{-1} \left( \frac{\text{height}}{b} \right) \quad (\text{Equation 5b})$$

Step 5: The equation for Vertex C in two dimensions:

$$C_x = \cos \theta (C_x - B_x) - \sin \theta (C_y - B_y) + B_x \quad (\text{Equation 6a})$$

$$C_y = \sin \theta (C_x - B_x) + \cos \theta (C_y - B_y) + B_y \quad (\text{Equation 6b})$$

Where  $C_x$  is the x-coordinate of vertex C  
 $C_y$  is the y-coordinate of the vertex C  
 $\theta$  is the angle of rotation

Step 6:

a. If angle was acute (False in our program)

i.  $A.x = C.x - b * \cos(\text{angle at vertex C})$

ii.  $A.y = C.y - b * \sin(\text{angle at vertex C})$

(Equation 7)

b. If angle was obtuse (True in our program)

i.  $A.x = B.x + c * \cos(\text{angle at vertex B})$

ii.  $A.y = B.y + c * \sin(\text{angle at vertex B})$

(Equation 8)

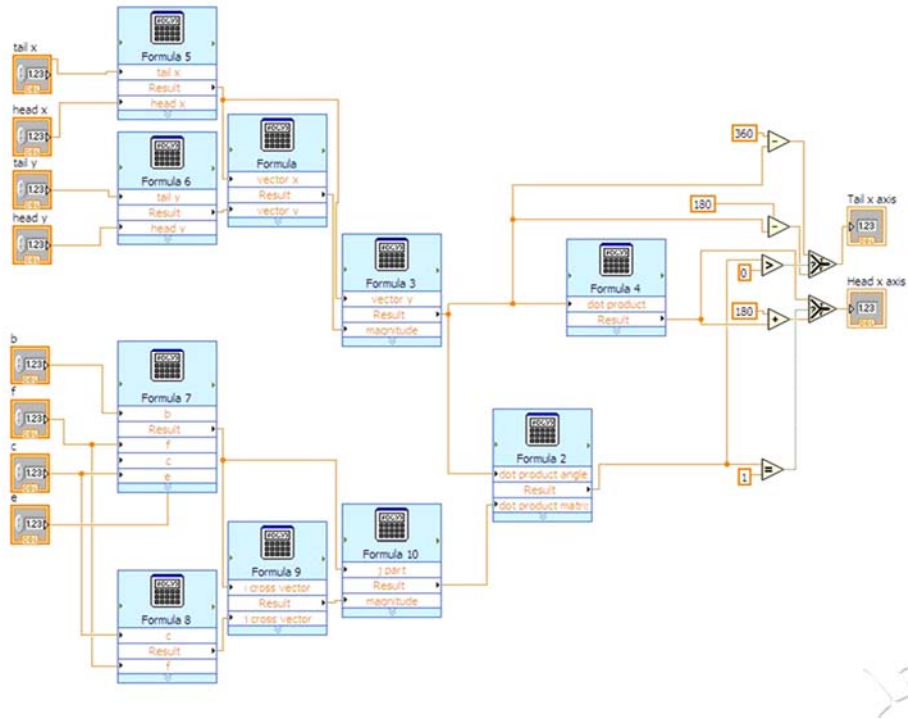

**Figure 8: Orientation Sub VI**

### Orientation formulas

The labVIEW sub VI shown in figure 8 incorporates the following formulas.

Step 1: Calculate the vector that connects the head and tail

$$\text{Vector.x} = \text{tail.x} - \text{head.x} \text{ (Equation 9a)}$$

$$\text{Vector.y} = \text{tail.y} - \text{head.y} \text{ (Equation 9b)}$$

$$\text{Magnitude} = \sqrt{\text{Vector.x}^2 + \text{Vector.y}^2} \text{ (Equation 10)}$$

Step 2: Calculate the unit vector components

$$x = \frac{\text{Vector } x}{\text{Magnitude}} \text{ (Equation 11a)}$$

$$y = \frac{\text{Vector } y}{\text{Magnitude}} \text{ (Equation 11b)}$$

Step 3: Obtain the vector made with reference to the y-axis and calculate the dot product.

a) Unit Vector for y - Axis (axis) = {0.0,1.0}

b) Dot product = Unit Vector.x \* axis.x + Unit Vector.y \* axis.y (Equation 12)

Step 4: Calculate the arc cosine of the dot product

$$y - \text{axis} - \theta = \cos^{-1}(\text{dot product}) \text{ (Equation 13)}$$



Step 5: Calculate the cross product to determine if the angle was in the clockwise or counter clockwise direction.

$$\text{Cross Product} = \begin{vmatrix} i & j & k \\ a & b & c \\ d & e & f \end{vmatrix} \quad (\text{Equation 14})$$

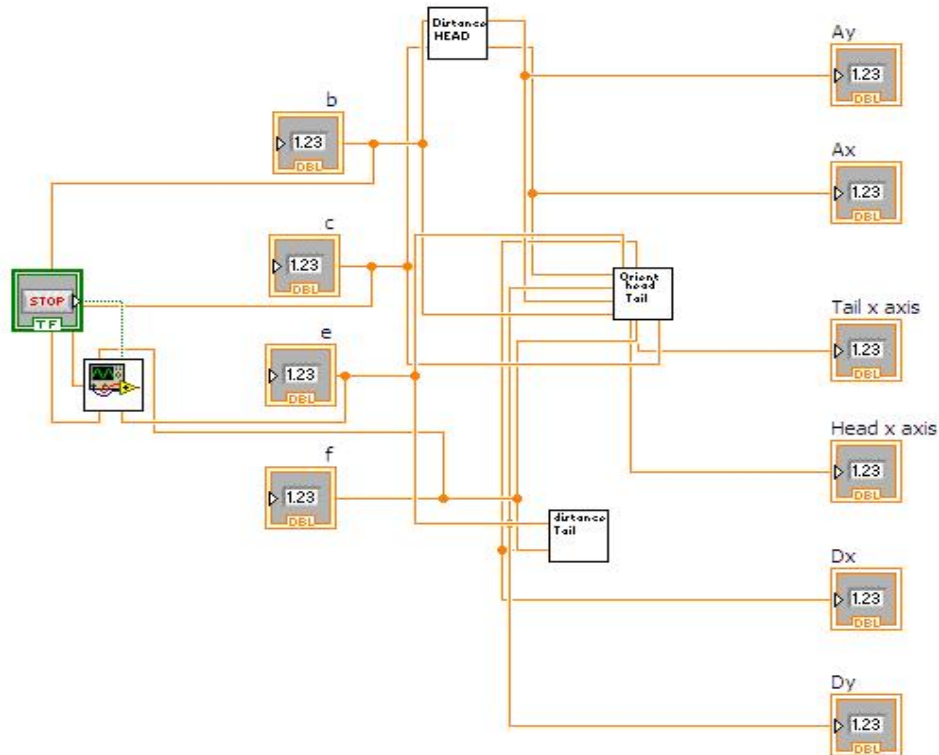

Figure 9: LabVIEW ultrasound Sub VI, with all distance and orientation calculations

## Conclusion

The LabVIEW virtual instruments, basic stamp programs and hardware were tested for functionality. Each of the programs functioned as expected. Further testing is warranted to assure reliable operation.

## References

- [1] Black, J.T. (1991). *The design of factory with a future*. McGraw-Hill
- [2] Yu, W. & Egbelu, P.J. (2001). "Design of a variable path tandem layout for automated guided vehicle system." *Journal of Manufacturing Systems*, 20.
- [3] Getting, I.A. (1993). "The global positioning systems." *IEEE Spectrum*, December, 33-47.
- [4] Siemens, Website: <http://www.ugvsystems.com/faqs/q6.htm>. Accessed on May 20, 2007.
- [5] Dixon, J. & Henlich, O. (2008). *Mobile robot navigation*. Website: [http://www.doc.ic.ac.uk/~nd/surprise\\_97/journal/vol4/jmd/](http://www.doc.ic.ac.uk/~nd/surprise_97/journal/vol4/jmd/) Imperial College, London. Accessed June 15, 2014.
- [6] Rathbone, R. R., Valley, R.A. & Kindlmann, P.J. (2000). "Beacon-referenced dead reckoning: a versatile guidance system." *Robotics Engineers*, 8, 11-16.

- [7] Miller, G.L., Wagner, E.R. & A.T. & T. Bell Laboratories (1988). "An optical rangefinder for autonomous robot cart navigation." *Society of Photo-Optical Instrumentation Engineers, Vol. 852*.
- [8] When, H.W. & Belanger, P.R. (1997). "Ultrasonic-based robot position estimation." *IEEE Transactions on Robotics and Automation, 13*, 682-692.
- [9] Mahajan, A. & Figueroa, F. (1999). "An automatic self installation and calibration method for 3D position sensing using ultrasonic." *Robotics and Autonomous Systems 28*, 281-294.
- [10] Ray, P.K., Unnikrishanan, N. & Mahajan, A. (2002). *Accuracy consideration in 3d ultrasonic positioning system based on the difference in time of flight*. Department of Mechanical Engineering and Energy Process, Southern Illinois University, Carbondale, IL.
- [11] Kuang, W.T. & Morris, A.S. (1999). "Algorithm for robot position tracking using ultrasonic." *Electronics Letters 35*.
- [12] Demirli, K. & Turksen, I.B. (2000). "Sonar based mobile robot localization by using fuzzy logic." *Robotics and Autonomous Systems, 33*, 109-123.
- [13] Shoval, S., Benchetrit, U., and Lenz, E., 1995, "Control and Positioning of a UGV for Material Handling in an Industrial Environment," *Manufacturing Systems, Vol. 25, No. 4*, 1996, pp. 405-40.
- [14] Borenstein, J., Everett, H.R., & Feng, L. (1996). *Navigating mobile robots: sensors and techniques*. A. K. Peters, Ltd.
- [15] Navro-Serment, A. E., Paredis, J. J. & Khosal, P.K. (2000). *A beacon system for the localization of distributed robotic teams*. The Institute for Complex Engineered Systems. Carnegie Mellon University. Pittsburgh, PA.
- [16] Cohen, C. and Koss, F., 1992, "A Comprehensive Study of Three Object Triangulation." *Proceedings of the 1993 SPIE Conference on Mobile Robots*, Boston, MA, Nov. 18-20, pp. 95-106.
- [17] Thamma, R. (2009). "Estimating Position and Orientation of an Unmanned Guided Vehicle with Ultrasound and Radio Frequency Sensing." *Journal of Technology Interface*. Special Edition, Winter 2009.
- [18] Thamma, R. (2008). "Navigational aids to predict the position of automated guided vehicles with ultrasound and radio frequency sensing." *Proceedings of the IAJC-IJME International Conference*, 154-165.
- [19] Dam, D. *Use Parallax Ping))) Ultrasonic Range Sensor with DAQmx*. Website: <https://decibel.ni.com/content/docs/DOC-8665>. Retrieved June 15, 2014.

## Biography

DR. RAVINDRA THAMMA is currently an Associate Professor of Robotics and Mechatronics at Central Connecticut State University. Dr. Thamma received his PhD from Iowa State University. His teaching and research interests are robotics, linear control systems and intelligent systems. He may be reached at [thammarav@mail.ccsu.edu](mailto:thammarav@mail.ccsu.edu).

DR. E. DANIEL KIRBY is currently an Associate Professor of Manufacturing at Central Connecticut State University. His teaching and research interests are in robotics flexible manufacturing systems, process optimization, and green manufacturing.

MR. GREGORY MARSHALL is currently a senior at Charter Oak State College studying a concentration in Technology Studies. His research interests are signal processing and linear control systems.

MR. HUGO CUERVO GARCIA is currently a student of University of Leon in Spain; he is studying Industrial Engineering as an exchange student with Central Connecticut State University.

DR. MARK RAJAI is currently a Professor of engineering at California State University- Northridge, and president of the International Association of Journals and Conferences.